

# SINEAX A 210 / A 220

## Multifunctional Power Monitor

武汉海瑞特自动化工程有限公司

H.R.T Automation Engineering

<http://www.herrett.com.cn>

Tel:027-87630899 Fax:027-87632899

**63 measured quantities**

**8 energy meters**

**5 average power values P, Q, S each**

### Application

The A 210/A 220 power measuring instrument is suitable for control panel mounting and measures all the important measurands in 3-phase and single-phase systems.

It displays the measurands with a high contrast 14 mm high LED display. The instrument is also suitable for measurements in high and middle voltage systems because of the freely programmable factors for the current and voltage transformers.

It replaces a large number of analog instruments and delivers high-accuracy values.

The basic execution is an instrument with 2 S0-outputs, which can be programmed as pulse or limit outputs. Extension modules increase the functionality and flexibility. The EMMOD 201 module has an RS232/RS485 interface and supports data exchange with a control system via MODBUS RTU. Memory and a digital input (switching between high and low tariffs) for monitoring, or the storage of average power values (load profile) complete the functionality. The user-friendly A200*plus* software supports parameter setting and reading the measured values.

The EMMOD202 has 2 galvanically isolated analog outputs. Any of the important input measurements can be assigned to the 4 - 20 or 0 - 20 mA signal, and it is possible to program an inverted characteristic.

EMMOD203 users can communicate with the Ethernet and Internet worlds with the MODBUS protocol over TCP/IP and HTTP. In addition, the module has an extensive memory, which supports backed up recordings for up to one year. The data are recorded with an exact time stamp, which is given by an internal, battery backed up clock.

Further modules are the EMMOD204 (Profibus-DP), the EMMOD205 (LON) and the EMMOD206 (M-Bus).

All the modules can be upgraded by simply plugging in the extension module without having to open the power monitoring instrument. A separate power supply is not required.

### Features

- Measurement of current, voltage, active, reactive and apparent power, active and reactive energy, neutral conductor current, power factor and frequency
- 4 meters for active power: Incoming/outgoing with high/low tariff
- 4 meters for reactive power: Inductive/capacitive with high/low tariff
- 5 values each for active, reactive and apparent power averages with programmable interval times



- Two S0-outputs for pulse or limit values
- Dimensions: SINEAX A 210: 96 x 96 x 46 mm  
SINEAX A 220: 144 x 144 x 46 mm
- Programmable conversion factors
- Flexible power supply with an AC/DC wide-range power supply unit
- Electrically isolated current inputs (1 A or 5 A)
- Upgrade extension modules with RS232/RS485 interface, load profile memory, MODBUS, synchronizing input, analog outputs, Ethernet, Profibus-DP or LON
- Accurate measured values for U, I  $\leq$  0.5%, F  $\leq$  0.02 Hz, others 1%
- Storage of minimum and maximum values
- Measurement in single-phase systems, 3-wire and 4-wire systems in 4 quadrant operation

### Benefits

- High functionality (63 measurand values) in a compact form (depth 46 mm)
- Therefore low costs for purchase, engineering and installation
- Safe 3-way galvanic isolation between all circuits and between the 3 current inputs
- Large LED display that can be read from a distance, especially suitable for badly lit rooms
- Robust front (IP 66) for tough industrial applications
- Storage of all counter values, the min./max. values, the display mode and the programmed data on failure of the power supply

# SINEAX A 210 / A 220

## Multifunctional Power Monitor

武汉海瑞特自动化工程有限公司  
 H.R.T Automation Engineering  
<http://www.herrett.com.cn>  
 Tel:027-87630899 Fax:027-87632899

### Function

The instrument measures the currents I1, I2, I3 and the voltages U1, U2, U3, the frequency, and the phase angles between the individual currents and voltages. All the other measurands are calculated from these. The measurements are made internally via integrated current transformers. Therefore it is possible to make direct connections without an external transformer.

Each input is sampled 32 times per cycle. This allows measurements to be made including up to the 15th harmonic.

The calculation of the measurands is made in accordance with DIN 40 110 part 1 and part 2, however in 4-quadrant operation.

In the figures at this data sheet only SINEAX A 210 is shown. Display and operating are identical with the A 220.

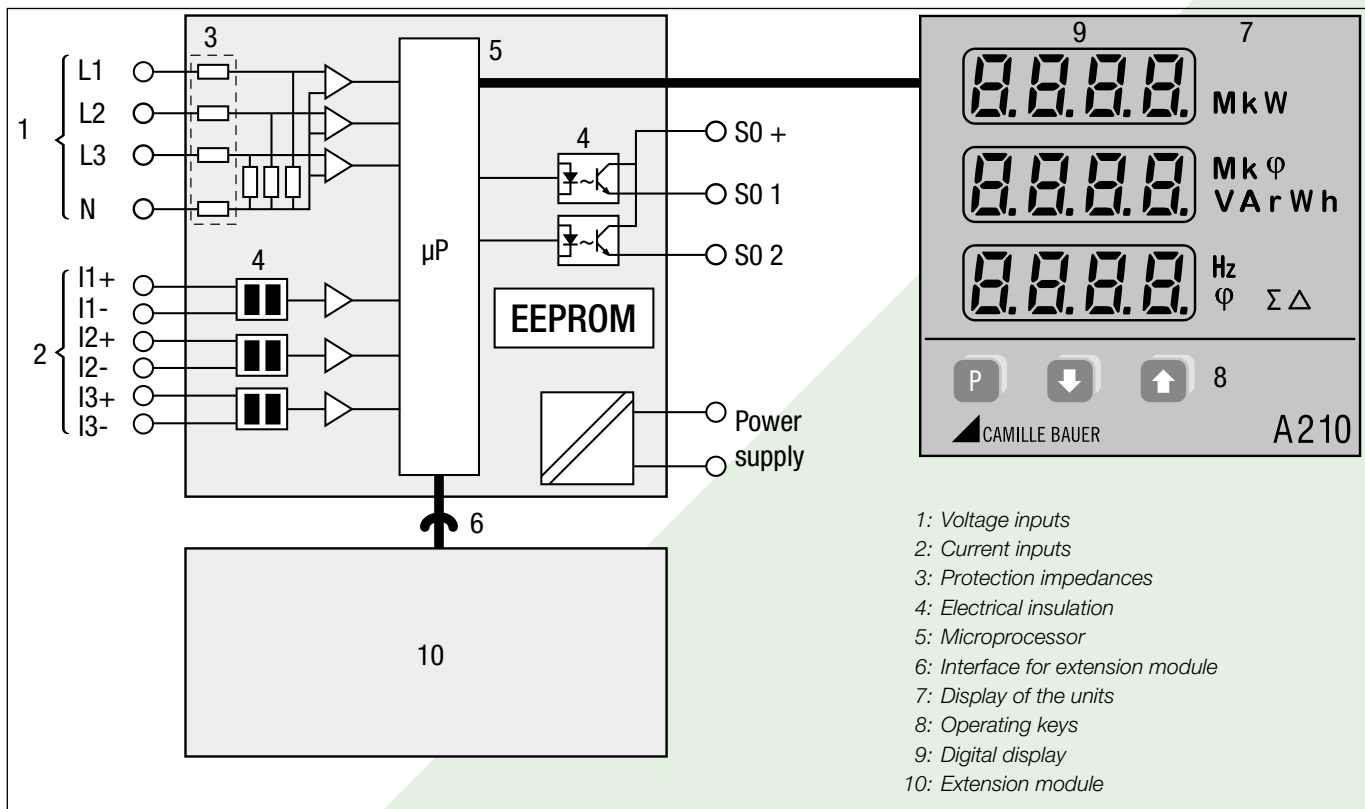
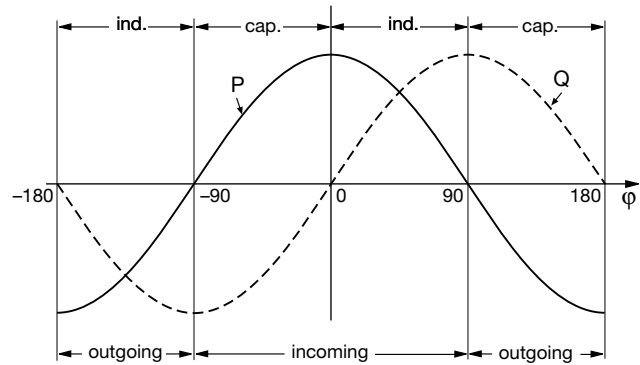

Fig. 1. Block diagram.

**Table 1: Standard versions**

The following transducer versions are available as standard versions. It is only necessary to quote the **Order No.:**

Description	Order Number A 210	Encoding item
500 V / 5 A, power supply 100 to 230 V AC/DC	149 783	210-121200
500 V / 5 A, power supply 24 to 60 V AC/DC	150 300	210-121100
500 V / 1 A, power supply 100 to 230 V AC/DC	152 447	210-111200

Please complete the Order Code 210-1... . acc. to "Table 2: Specification and ordering information" for versions with user-specific input ranges and/or variable sensitivity.

**Table 2: Specification and ordering information** (see also Table 1: "Standard versions")

Description	Feature
<b>SINEAX A210, Multifunctional power monitor, size 96 x 96 mm</b>	210-
<b>SINEAX A220, Multifunctional power monitor, size 144 x 144 mm</b>	220-
<b>Features, Selection</b>	
<b>1. Nominal voltage</b> 500 V (Ph-Ph), 290 V (Ph-N): Overload ≤20%	1
<b>2. Nominal current</b> 1 A	1
5 A	2
<b>3. Nominal frequency</b> 50 / 60 Hz	1
<b>4. Power supply</b> 24...60 V AC/DC	1
100...230 V AC/DC	2
<b>5. Test certificate</b> Without test certificate	0
Test certificate German	D
Test certificate Englisch	E
<b>6. Built-on extension module</b> Without	0
EMMOD 201 Interface MODBUS/RTU, data logger, digital input	1
EMMOD 202 2 analog outputs	2
EMMOD 203 Ethernet, real-time clock, 2 digital inputs, 2 MB data logger	3
EMMOD 204 Interface Profibus-DP	4
EMMOD 205 Interface LON, digital input	5
EMMOD 205 Interface LON, digital output 125 V, direct connection to summation station U160x of Gossen-Metrawatt possible"	6
	7
EMMOD 206 Interface M-Bus, digital input <230 V AC/DC	8

# SINEAX A 210 / A 220

## Multifunctional Power Monitor

武汉海瑞特自动化工程有限公司  
H.R.T Automation Engineering  
<http://www.herrett.com.cn>  
Tel:027-87630899 Fax:027-87632899

### Technical data

#### System/application

Single-phase, 3-wire balanced or unbalanced, 4-wire balanced or unbalanced, 4-quadrant operation

#### Measurements available

Measured quantities	Measuring path	max	min
Voltage	1-N, 2-N, 3-N	●	●
Voltage	1-2, 2-3, 3-1	●	●
Current	1, 2, 3, N	●	
Current $I_{avg}$ (bimetal -15 min/ slave pointer)	1, 2, 3	●	
Active power P	1, 2, 3, $\Sigma$	●	
Reactive power Q	1, 2, 3, $\Sigma$	●	
Apparent power S	1, 2, 3, $\Sigma$	●	
$\cos\varphi$ (4-quadrant display)	1, 2, 3, $\Sigma$		
$\cos\varphi$ inductive min.	1, 2, 3		●
$\cos\varphi$ capacitive min.	1, 2, 3		●
Frequency	U, I		
P-meter incoming/outgoing (HT/ NT)	$\Sigma$		
Q-meter ind./cap. (HT/NT)	$\Sigma$		
5 active power interval value	$\Sigma$		
5 reactive power interval values	$\Sigma$		
5 apparent power interval values	$\Sigma$		

#### Programmable values (basic unit)

Trip points, pulse rate, transformer ratio, type of system, interval time for average power values.

Programming can be locked with a jumper at the back of the instrument.

However, the limit values can still be changed.

All min. and max. values and the counter values can be reset. The resetting of the counter values can also be blocked with the above mentioned jumper.

All the measurands, the selected display, the counter values and the programmed data are kept on a power failure.

#### Factory default

Brightness:	(mid setting)
Limit value / S01:	Off
Limit value / S02:	Off
Transformer ratio:	1 : 1
Jumper:	Not in the LOCK position
Connecting mode:	4-wire asymmetric load
Synchronizing interval:	15 min.

#### Applicable regulations and standards

IEC 1010 resp. EN 61 010 Safety regulations for electrical measuring, control and laboratory equipment

EN 60 529	Protection types by case
DIN 43 864	Current interface for the transmission of impulses between impulse encoder counter and tarif meter (S0 output)
DIN 40 110	AC quantities
IEC/EN 61326-1 IEC/EN 61326/A1	Electrical equipment for measurement, control and laboratory use, EMC requirements
EN 60 688	Electrical measuring transducers for converting AC electrical variables into analogue and digital signals
IEC 68-2-1/-2/-3/-6/-27 resp. EN 60 068-2-1/-2/-3/-6/-27	Ambient tests -1 Cold, -2 Dry heat, -3 Damp heat, -6 Vibration, -27 Shock

#### Measuring inputs

Nominal frequency:	50, 60 Hz
Nominal input voltage:	Phase-phase: 500 V Phase-N: 290 V
Nominal input current:	5 A or 1 A
Waveform:	Sine
Own consumption:	Current circuit: $\leq I^2 \cdot 0.01 \Omega$ Voltage circuit: $\leq \frac{U_{LN}^2}{300 \text{ k}\Omega}$

#### Continuous overload withstand

10 A at 346 V in single-phase AC system  
10 A at 600 V in three-phase system

#### Short duration overload withstand

Input variable	Number of applications	Duration of overload	Interval between two overloads
577 V LN	10	1 s	10 s
100 A	10	1 s	100 s
100 A	5	3 s	5 min.

#### Measuring range

U, I, S:	$\leq 120\%$ of nominal value
P, Q:	$\leq \pm 120\%$ of nominal value
F:	45 to 65 Hz
$\cos\varphi$ :	$\pm 1$
Overload indicator:	oL

The frequency is measured from the current or voltage. The voltage has priority.

### Pulse/limit value outputs

Depending on the function selected, the two digital outputs can be used either as pulse outputs for active and reactive energy or as limit signals.

The outputs are passive, and are galvanically isolated from all the other circuits by opto-couplers. They are suitable to drive tariff devices (S0-standard DIN 43 864) or 24 V-relais.

$U_{ext} \leq 40 \text{ V DC}$  (OFF: leakage current  $\leq 0.1 \text{ mA}$ )  
 $I_L \leq 150 \text{ mA}$  (ON: terminal voltage  $\leq 1.2 \text{ V}$ )

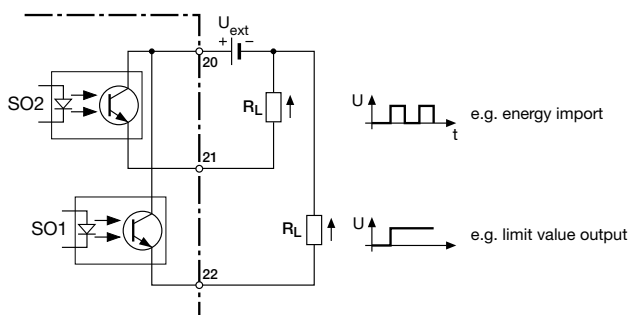

### Limit value outputs:

the limits can be associated with any measurand. Depending on the type of connection an OR or an AND function is possible for the following values.

3-wire unbalanced load:  $U_{12}/U_{23}/U_{31}, I_1/I_2/I_3, I_{avg1}/I_{avg2}/I_{avg3}$

4-wire unbalanced load:  $U_1/U_2/U_3, U_{12}/U_{23}/U_{31}, I_1/I_2/I_3, I_{avg1}/I_{avg2}/I_{avg3}, P_1/P_2/P_3, Q_1/Q_2/Q_3, S_1/S_2/S_3, PF_1/PF_2/PF_3$

Alarm ON: OR function of the phase measurands

Alarm OFF: AND function of the phase measurands

Delay time: Fixed at 1 s (cannot be modified)

### Pulse outputs:

The reactive and active energy can be read out at the pulse outputs in the form of standard S0 pulses for the driving of electronic and electromechanical counting mechanisms.

The pulse rate is programmable:

1 ... 5000 Imp./Wh ... GWh resp. 1 ... 5000 Imp/varh ... Gvarh

The duration of the pulses cannot be programmed and also cannot be changed by hardware means.

Pulse duration:  $> 100 \text{ ms}$

For systems with external transformers, the pulses are for the primary energy data.

### Power supply

DC, AC power pack 50 to 400 Hz

100 to 230 V AC/DC  $\pm 15\%$  or 24 to 60 V AC/DC  $\pm 15\%$  (UL) 85 to 125 V DC

Power consumption:  $< 3 \text{ VA}$  (without interface module)

### Display

14 mm LED digital display; adjustable brightness

3 digits with sign, frequency: 4 digits, energy: 8 digits

Colour: red

### Zero value suppression

PF resp.  $\cos\phi$ :

Display ---, if  $S_x < 0.2\% S_{nenn}$

Currents:

Display 0, if  $I_x < 0.1\% I_{nenn}$

### Example of the display for 4-quadrant measurements

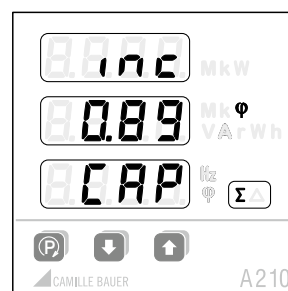

System

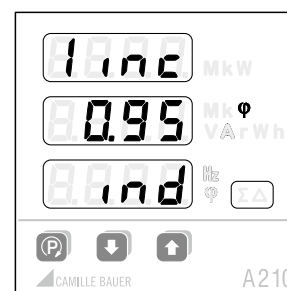

Phase 1

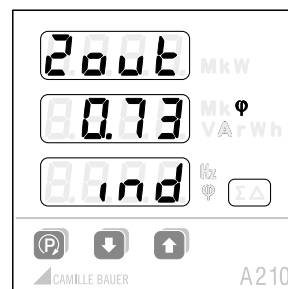

Phase 2

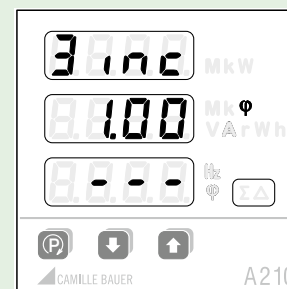

Phase 3

**ind** inductive  
**CAP** capacitive

**inc** incoming  
**out** outgoing

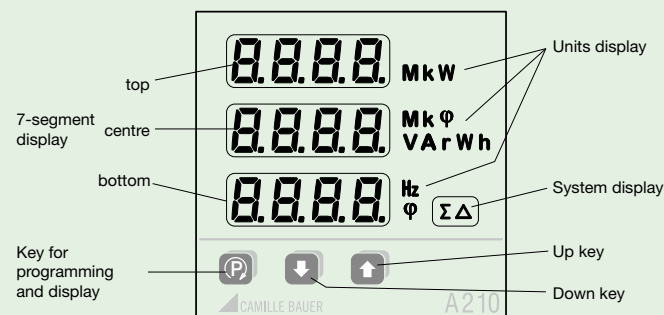

# SINEAX A 210 / A 220

## Multifunctional Power Monitor

武汉海瑞特自动化工程有限公司  
H.R.T Automation Engineering  
<http://www.herrett.com.cn>  
Tel:027-87630899 Fax:027-87632899

Display levels: e.g. 4-wire unbalanced load

		a	b	c	d	e	f
 	1	U1 U2 U3	U1 <sub>max.</sub> U2 <sub>max.</sub> U3 <sub>max.</sub>	U1 <sub>min.</sub> U2 <sub>min.</sub> U3 <sub>min.</sub>	U12 U23 U31	U12 <sub>max.</sub> U23 <sub>max.</sub> U31 <sub>max.</sub>	U12 <sub>min.</sub> U23 <sub>min.</sub> U31 <sub>min.</sub>
	2	I1 I2 I3	I1 <sub>max.</sub> I2 <sub>max.</sub> I3 <sub>max.</sub>	I1 <sub>avg.</sub> I2 <sub>avg.</sub> I3 <sub>avg.</sub>	I1 <sub>avgmax.</sub> I2 <sub>avgmax.</sub> I3 <sub>avgmax.</sub>	IN	IN <sub>max.</sub>
	3	P1 P2 P3	P1 <sub>max.</sub> P2 <sub>max.</sub> P3 <sub>max.</sub>	P	P <sub>max.</sub>		
	4	Q1 Q2 Q3	Q1 <sub>max.</sub> Q2 <sub>max.</sub> Q3 <sub>max.</sub>	Q	Q <sub>max.</sub>		
	5	S1 S2 S3	S1 <sub>max.</sub> S2 <sub>max.</sub> S3 <sub>max.</sub>	S	S <sub>max.</sub>		
	6	PF1	PF2	PF3	PF	PF <sub>minind</sub>	PF <sub>mincap</sub>
	7	F					
	8	EPinc HT <sup>1</sup>	EP inc LT <sup>2</sup>	EP out HT <sup>1</sup>	EP out LT <sup>2</sup>		
	9	EQ ind HT <sup>1</sup>	EQ ind LT <sup>2</sup>	EQ cap HT <sup>1</sup>	EQ cap LT <sup>2</sup>		
	10	P Q PF	P S F				
	11	Pint0	Pint1	Pint2	Pint3	Pint4	
	12	Qint0	Qint1	Qint2	Qint3	Qint4	
	13	Sint0	Sint1	Sint2	Sint3	Sint4	

<sup>1</sup> HT = High tariff

<sup>2</sup> LT = Low tariff

### Safety

Protection class: II (voltage inputs with protection impedances)

Measuring category: III

Pollution degree: 2

Measurement voltage: 300 V

Test voltage: Between current inputs, power supply, digital outputs, terminals of the plugged-in module: 3700 V / 50 Hz / 1 min.

On voltage inputs:  
4.25 kV 1.2/50 μs

Module connections: The pin rail at the back is connected to the voltage inputs via a protection impedance. Only the permitted modules can be plugged-in!

Enclosure protection: Front IP 66, terminals IP 20

Inputs, outputs and power supply are electrically isolated. The current inputs are electrically isolated from each other.

### Accuracy data

Reference conditions acc. to IEC 688 resp. EN 60 688

Sine 50 - 60 Hz, 15 - 30°C, application group II

Measurement accuracy (related to nominal value)

Current, voltage	± 0.5%
Power	± 1.0%
Power factor	± 1.0%
Energy	± 1.0%
Frequency	± 0.02 Hz (abs.)

### Mechanic

Dimensions	A 210:	96 x 96 x 46 mm; Panel cutout 92 <sup>+0.8</sup> x 92 <sup>+0.8</sup> mm
	A 220:	144 x 144 x 46 mm; Panel cutout 138 <sup>+1</sup> x 138 <sup>+1</sup> mm

### Terminals:

Inputs	Screw terminals Wire gauge single wire: 0.5 - 2.5 mm <sup>2</sup> Wire gauge fine wire: 0.5 - 1.5 mm <sup>2</sup>
Power supply, outputs	Clamps Wire gauge single and fine wire: 0.5 - 1.5 mm <sup>2</sup>

Housing material: ABS  
flammability class V-0 acc. to UL 94, self-extinguishing, non-dripping, free of halogen

Weight: 250 g at A 210 resp.  
300 g at A 220

Mounting: For control panel mounting

### Environmental conditions

Operating temperature: - 10 to + 55 °C

Storage temperature: - 25 to + 70 °C

Humidity relative: ≤ 75%

Altitude: 2000 m max.

Indoor use statement

## Electrical connections

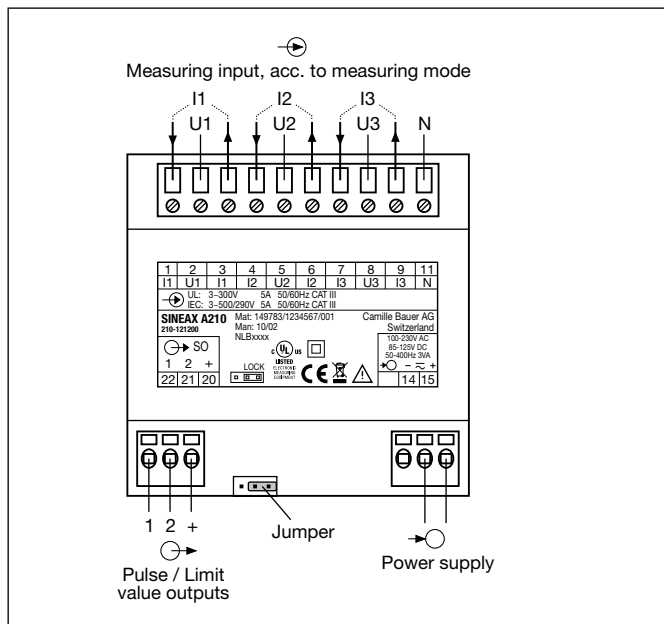

## Connecting modes

System / application	Terminals																	
Single-phase AC system  																		
3-wire, 3-phase symmetric load I: L1  	<p>Connect the voltage according to the following table for current measurement in L2 or L3:</p> <table border="1"> <thead> <tr> <th>Current transf.</th> <th>Terminals</th> <th>2</th> <th>5</th> <th>8</th> </tr> </thead> <tbody> <tr> <td>L2</td> <td>1</td> <td>3</td> <td>L2</td> <td>L3</td> <td>L1</td> </tr> <tr> <td>L3</td> <td>1</td> <td>3</td> <td>L3</td> <td>L1</td> <td>L2</td> </tr> </tbody> </table>	Current transf.	Terminals	2	5	8	L2	1	3	L2	L3	L1	L3	1	3	L3	L1	L2
Current transf.	Terminals	2	5	8														
L2	1	3	L2	L3	L1													
L3	1	3	L3	L1	L2													

System / application	Terminals														
3-wire 3 phase asymmetric load  															
4-wire 3 phase symmetric load I: L1  	<p>Connect the voltage according to the following table for current measurement in L2 or L3:</p> <table border="1"> <thead> <tr> <th>Current transf.</th> <th>Terminals</th> <th>2</th> <th>11</th> </tr> </thead> <tbody> <tr> <td>L2</td> <td>1</td> <td>3</td> <td>L2</td> <td>N</td> </tr> <tr> <td>L3</td> <td>1</td> <td>3</td> <td>L3</td> <td>N</td> </tr> </tbody> </table>	Current transf.	Terminals	2	11	L2	1	3	L2	N	L3	1	3	L3	N
Current transf.	Terminals	2	11												
L2	1	3	L2	N											
L3	1	3	L3	N											
4-wire 3 phase asymmetric load  	<p>3 single-pole insulated voltage transformers in high-voltage system</p>														

# SINEAX A 210 / A 220

## Multifunctional Power Monitor

武汉海瑞特自动化工程有限公司  
 H.R.T Automation Engineering  
<http://www.herrett.com.cn>  
 Tel:027-87630899 Fax:027-87632899

### Maintenance

No maintenance is required.

### Dimensional drawings (all dimensions in mm)

#### SINEAX A 210

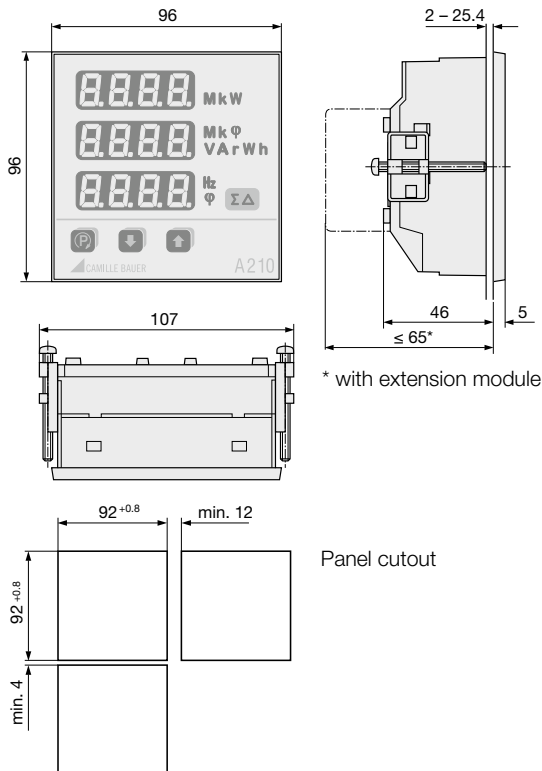

\* with extension module

Panel cutout

#### SINEAX A 220

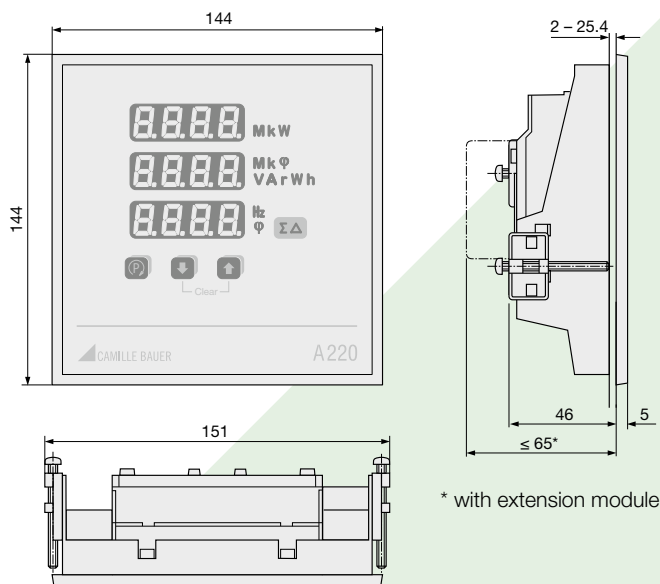

\* with extension module

Panel cutout 138<sup>+1</sup> x 138<sup>+1</sup> mm  
 Side by side mounting possible

### Scope of supply

Basic unit with/without extension module

Operating Instructions in German, French and English  
 Fixing clamp

Measuring protocol at instruments with order No.:

A 210: 150 318, 150 326, 152 710 and 152 728

A 220: 152 562, 152 570, 152 752 and 152 744

### Accessories SINEAX A 210/A 220

Description	Article No.
Operating Instructions in German, French and English	151 118
Top-hat rail adapter (A 210 only)	154 055
Extension module EMMOD 201 Interface/MODBUS RTU/data logger	150 285
Extension module EMMOD 202 2 analog outputs	155 574
Extension module EMMOD 203 Ethernet, 2 MB memory, real-time clock	155 582
Extension module EMMOD 204 Profibus-DP	158 510
Extension module EMMOD 205 LON, digital output 125 V, direct connection to summation stations U160x of Gossen-Metrawatt possible	156 647
Extension module EMMOD 205 LON, synchronizing input	156 639
Extension module EMMOD 206 Interface M-Bus, digital input <230 V AC/DC	168 965
Fixing clips as set (4 pce.) for top-hat rail adapter with extension module (A 210 only)	154 394

### Extension module EMMOD 201

#### Communication

Interface: RS232/RS485 switchable  
 Protocol: MODBUS RTU for SCADA  
 Digital input: Synchronizing input for average power values or switching between high/low tariff for the energy counters  
 Bus interface address: 1 to 247  
 Baudrate: 1200, 2400, 4800, 9600, 19.2 k  
 Parity check: no, even, odd, space

#### Recording average power values

Values that can be recorded:  
 Pint: active power average value with sign (incoming + / outgoing -)  
 Qint: reactive power average value (inductive + / capacitive +)

Amount of data  
 at 15 min intervals: 1 value (Pint or Qint) = 166 days  
 2 values (Pint and Qint) = 83 days



### Accessories EMMOD 201 (not included in scope of supply)

Description	Article No.
Software A200plus *)	146 557
Interface adapter cable	152 603
Extension cable sub-D 9pol. 2 m	980 179

\*) Download free of charge under <http://www.camillebauer.com>

### Dimensional drawing

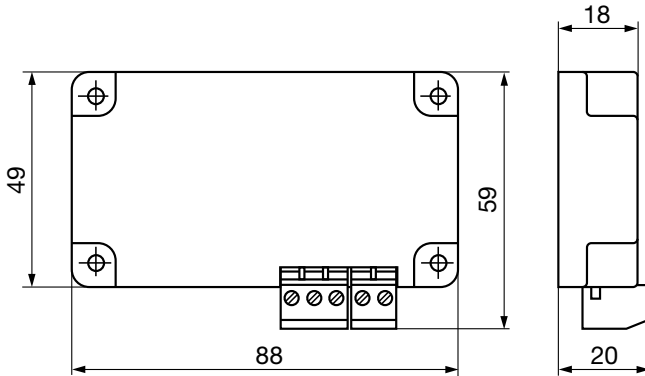

### Extension module EMMOD 202

Input: U, I, Iavg, In, P, Q, S, F, cosφ  
Output: 0 - 20 mA, 4 - 20 mA, inverting  
Limitation: 0/3.7 mA resp. 21 mA  
Burden voltage: 8 V  
Accuracy: 0.1% (without A2..)  
Number of channels: 2 (electrically isolated)

### Dimensional drawing

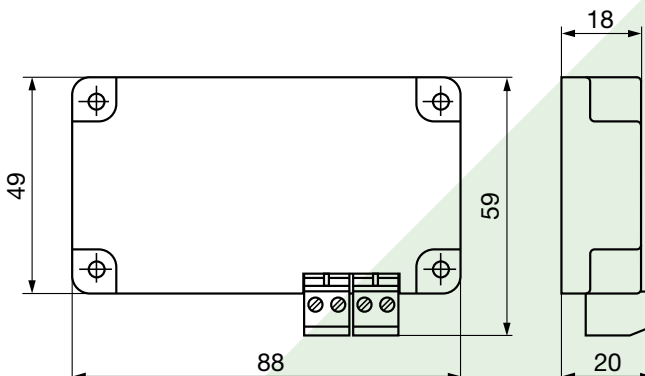

### Extension module EMMOD 203

Protocol: MODBUS over TCP/IP, HTTP  
Real-time clock: Battery backup, synchronised via LAN or external (e.g. 230 V/50 Hz)

Memory: Up to one year with time stamp

### Connections

Ethernet RJ45-port: 10/100 base Tx  
Tariff switching: Plug-in screw terminals  
Synchronizing input: Plug-in screw terminals  
Synchronizing input: 5 V - 300 V AC, 1 - 500 Hz  
Tariff switching: 5 V - 300 V AC/DC

### Dimensional drawing

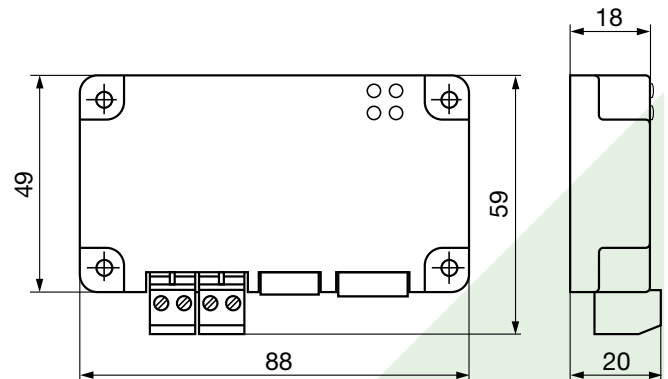

### Accessories EMMOD 203 (not included in scope of supply)

Description	Article No.
Software A200plus *)	146 557

\*) Download free of charge under <http://www.camillebauer.com>

### Extension module EMMOD 204

Interface: Profibus-DP  
9-pin D-sub socket  
EIA RS485 standard  
15 kV ESD protection  
Baudrate: Autom. recognition,  
9600 bit/s ... 12 Mbit/s  
Type: DPV0, SPC4-2  
Repeater\_Ctrl\_Sig (TTL)  
Address: 126 (0 - 125)  
Set\_Slave\_Add\_Supp

### Dimensional drawing

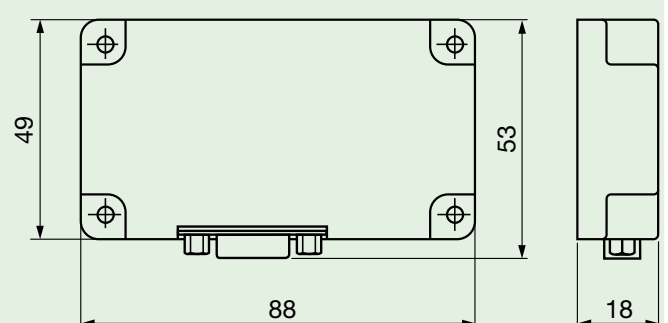

# SINEAX A 210 / A 220

## Multifunctional Power Monitor

武汉海瑞特自动化工程有限公司  
 H.R.T Automation Engineering  
<http://www.herrett.com.cn>  
 Tel:027-87630899 Fax:027-87632899

### Accessories EMMOD 204 (not included in scope of supply)

Description	Article No.
Profibus CD (GSD and documentation) *)	156 027

\*) Download free of charge under <http://www.camillebauer.com>

### Extension module EMMOD 205

#### Communication

Interface: LON  
 Protocol: LONTALK®  
 Medium: Echelon FTT-10A transceiver, transformer-coupled, reverse polarity, twisted two-wire cable  
 Transmission: 78 kBit/s

#### Connections

Bus: Pluggable screw terminals  
 I/O connector: Digital synchronization input or Digital output 125 V DC

#### Dimensional drawing

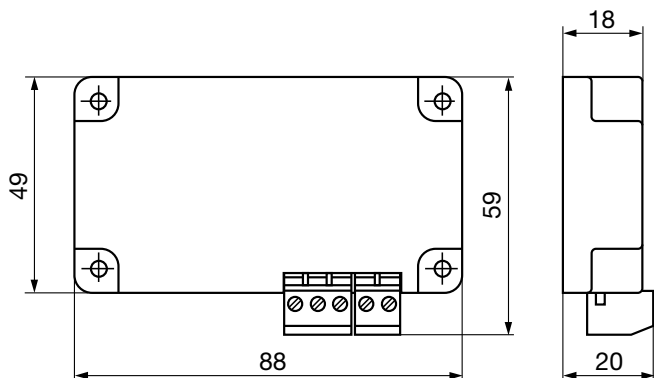

### Extension module EMMOD 206

#### Communication

Interface: M-Bus  
 Protocol: M-Bus  
 Baud rate: 300...38'400 Baud

#### Connections

Bus: Pluggable screw terminals  
 Digital input: Pluggable screw terminals for mean-value synchronization or tariff switching

#### Dimensional drawing

